



Fiberglass Hinged Patio Doors -Outswing



4 5/16"
(110)

Sill

Lock Actuator

Interior Active
Escutcheon Plate

Interior Active Escutcheon Plate

Install the screw first

Spindle

Bushing

Handle

Door Panel

Flat Blade
Screwdriver





Lock Mechanism

Hinged Patio Doors - Outswing

Installation and Finishing Instruction

IMPORTANT: Please read and follow all instructions before beginning. For any questions, contact your local Neuma Doors representative.

Material required to prepare :

- Shims / spacers (12 to 20) 
- 2" galvanized roofing nails (1/4 lb.) 
- 4" wide water resistance adhesive membrane 
- Silicone Sealant 
- Interior trim and / or jamb extensions (15 to 40 ft)
- #10x3" installation screws 

Tools Required:

- Tape measure 
- 6' Level 
- Square 
- Hammer 
- Stapler 
- Scissors or utility knife 
- Screwdrivers
(#2 Phillips & small flat blade) 
- Drill 
- 13/32" & 1/8" Drill Bits 

1. ROUGH OPENING INSPECTION AND PREPARATION

- The rough opening should be 3/4" wider than the frame width, and 1/2" higher than the frame height.
- Check sill for level and smooth. Clean away all debris before setting door assembly. (See Fig.1)
- Check rough opening for plumb and square by measuring diagonal. If it is not, correct as necessary. (See Fig.1)

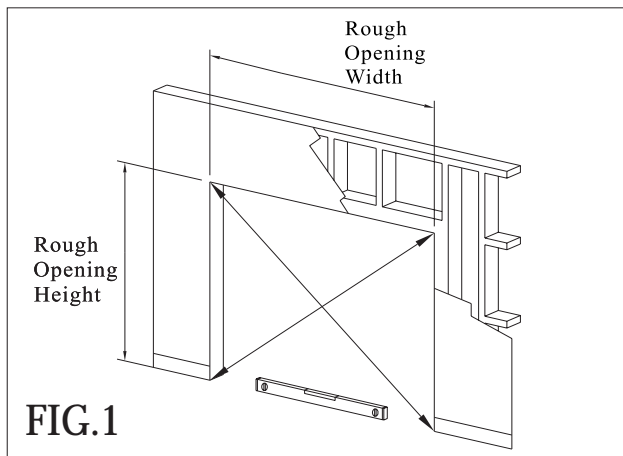

2. INSTALLING UNIT

- Carefully ensure the active door panel is locked before installation.
- Standard lock set
Use flat blade screwdriver to lock dead bolt. (See Fig.2)

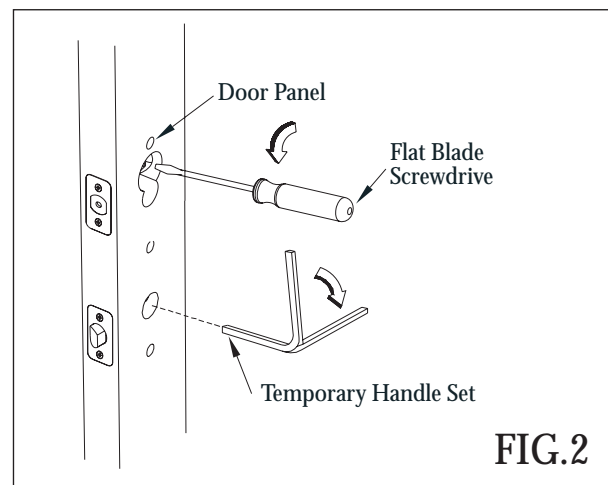

- Opening the multi-point lockset

Active Panel

First insert temporary handle into the lower hole and lift handle to lock the multi-point lock. With the handle in the lifted position insert a flat blade screwdriver into the upper hole. To disengage the deadbolt turn the screwdriver so the slot is in the horizontal position. To then unlock the multi-point lock and the latch. (See Fig.3)

Passive Panel

First insert temporary handle into the lower hole and lift handle to lock the bolts into the head jamb and sill. Pull handle down to disengage bolts (See Fig.3)

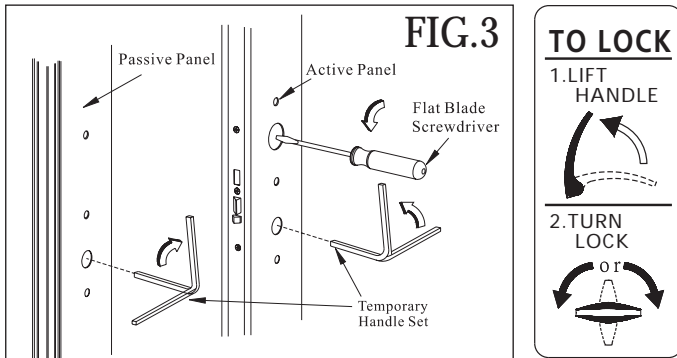

- Apply sealant into nailing fin grooves at head and jamb then snap in nailing fins. (See Fig.4a)
- Apply sealant in a continuous bead on the interior side of the nailing fin along the pre-punched holes. (See Fig.4)

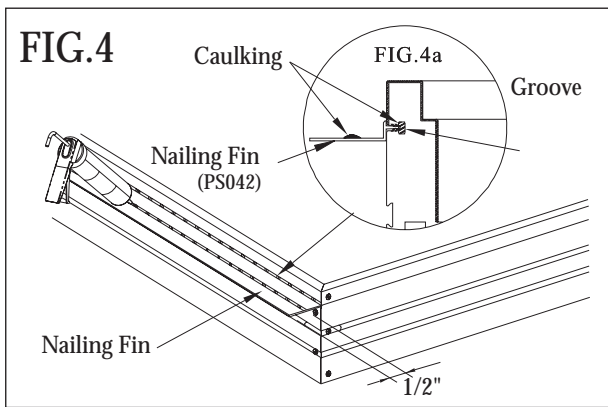

- Apply sufficient amount of sealant along the entire length of the sub floor and 6" up each side of jambs. (See Fig.5)
- Move door frame into rough opening, and center it. Temporarily fix an upper corner of the nailing fin with a 2" roofing nail and secure the same corner of head jamb with a #10x3" flat head screw from the interior side. (See Fig.6)

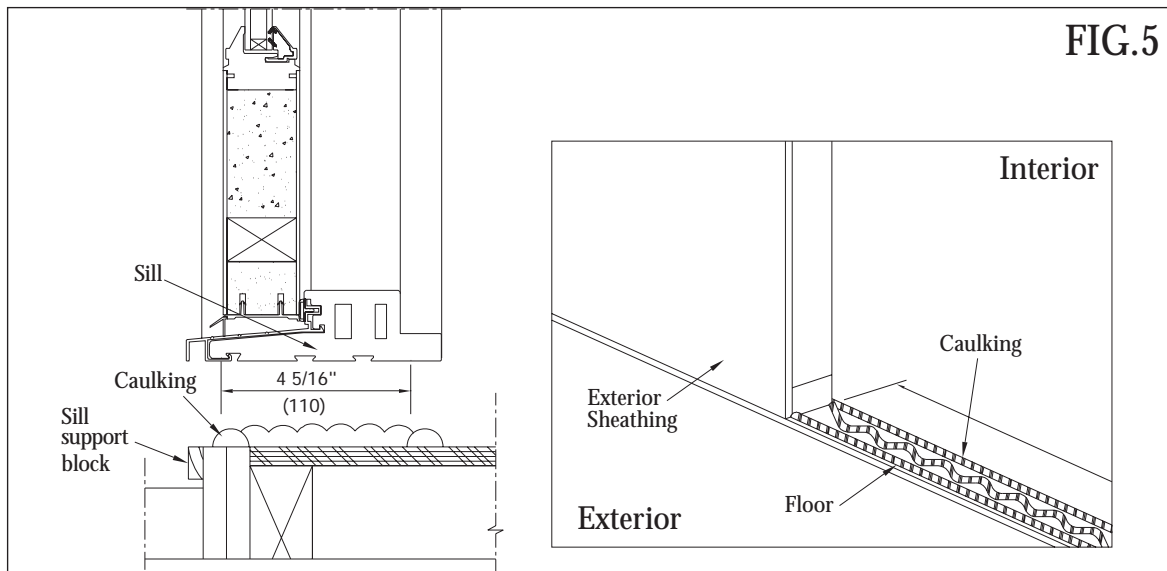
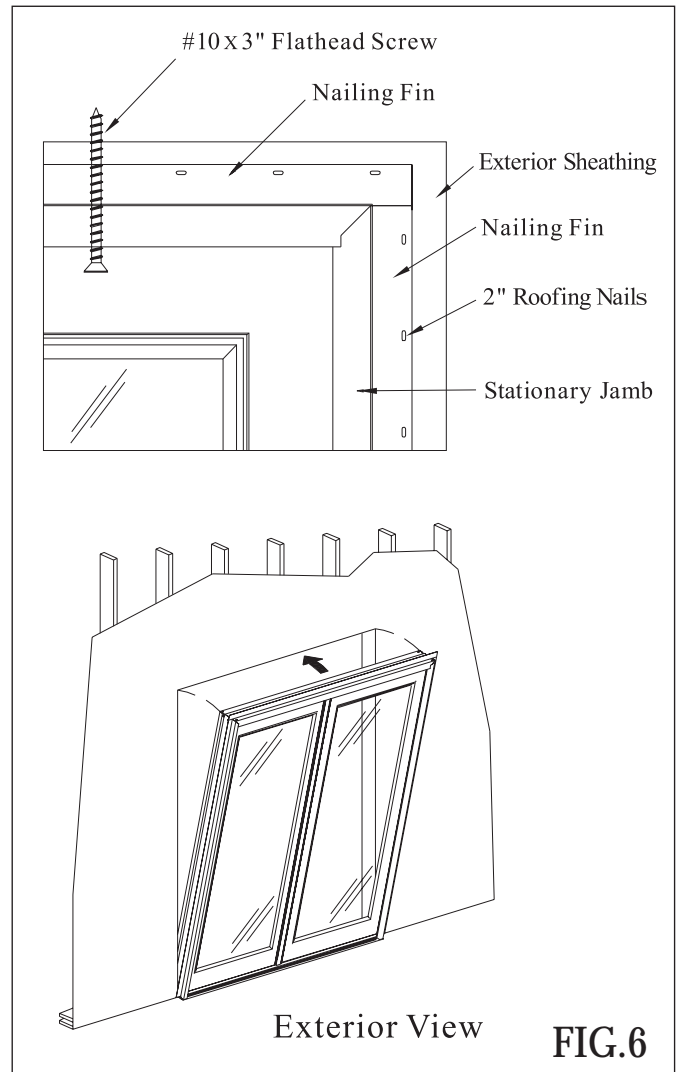

- Use level to check if the jambs are straight and plumb. The sill must be leveled and straight. Make sure the diagonal measurements of the entire frame are equal. Shim the corners 4" from the sill and head jamb. (See Fig.7)

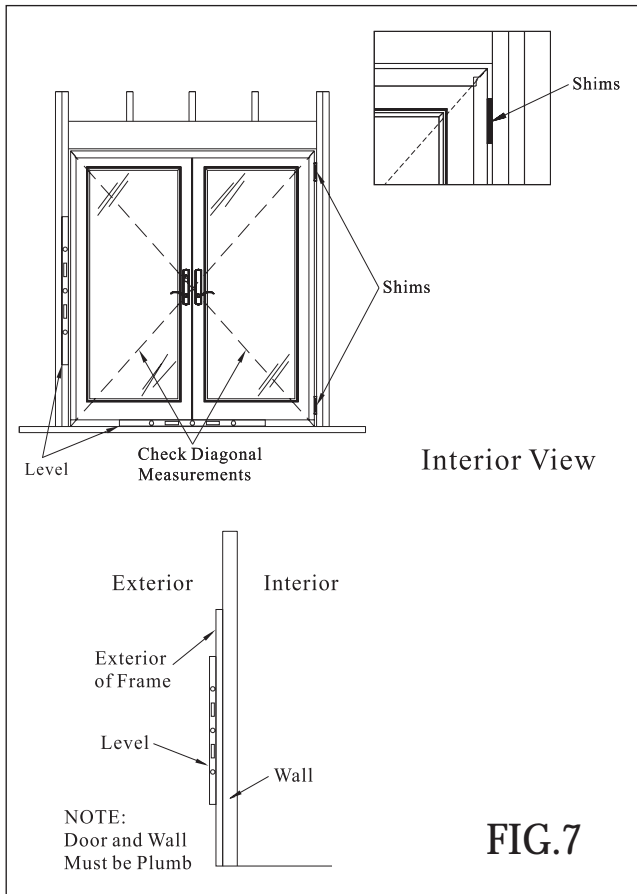

Use #10 x 3" flat head screw to secure the unit through the pre-drilled pilot holes through jambs. (See Fig.11) If unit is not pre-drilled use 1/8" bit to drill through jambs and studs at shim location. Use 13/32" bit to enlarge pre-drilled holes 1/4" deep into jambs for plug covers. (See Fig.12)

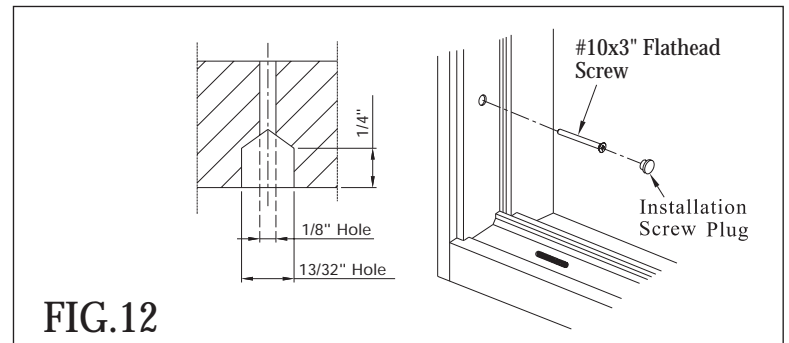
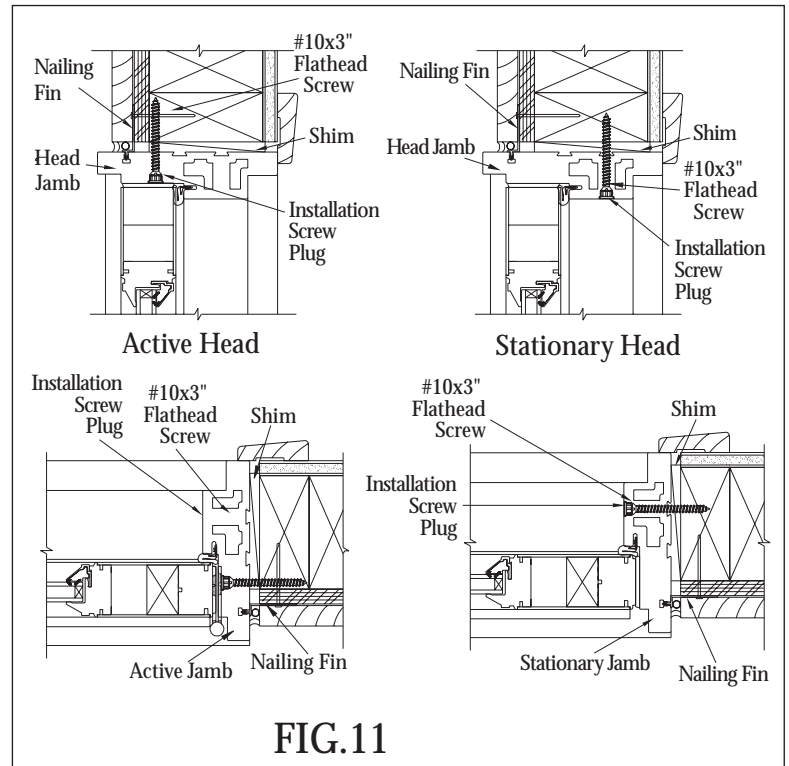

3. FASTEN UNIT

- Shim the jambs 4" down from top and up from sill. Place additional shims every 18", 19", 22" around jambs. (See Fig.8, Fig.9, and Fig.10). Shim at keeper location. If installation pilot holes are drilled shim at these locations. Recheck plumb level and square and adjust as necessary. Place fasteners in all pre-punched holes in installation fin approximately every 7-1/4".

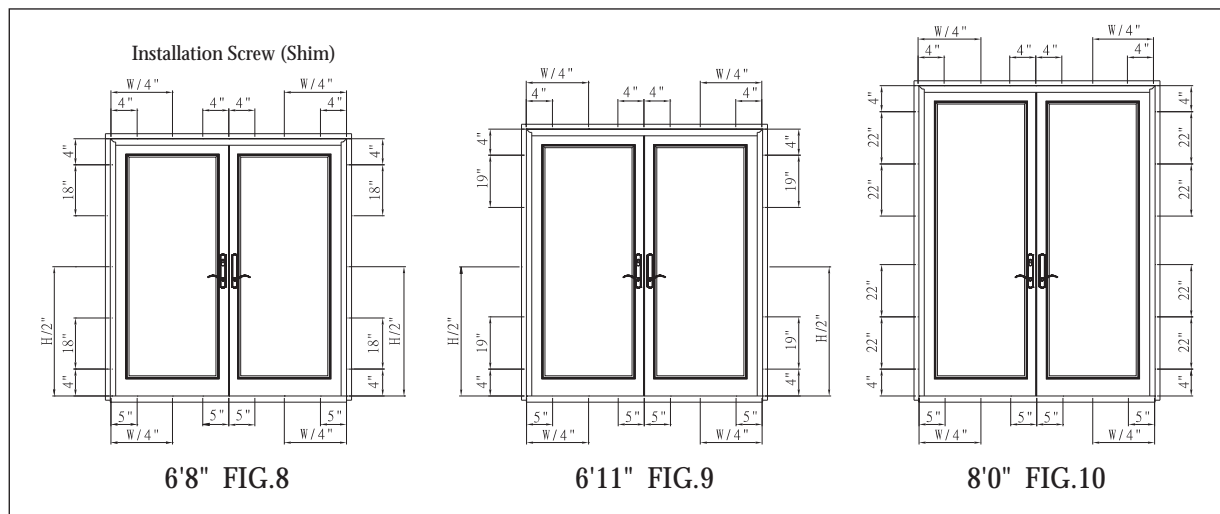

4. INSTALL HARDWARE

- Assemble handle spindle. (See Fig.13)

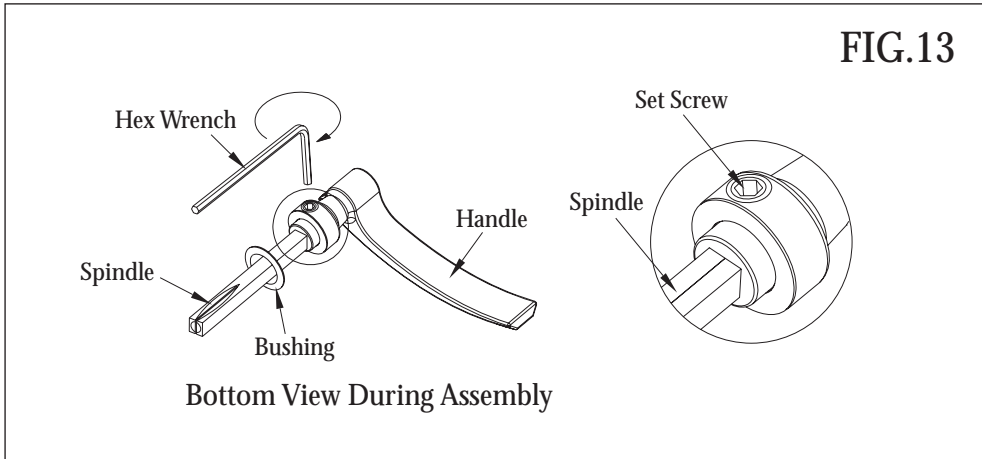

- Standard lock handle set. (See Fig.14)

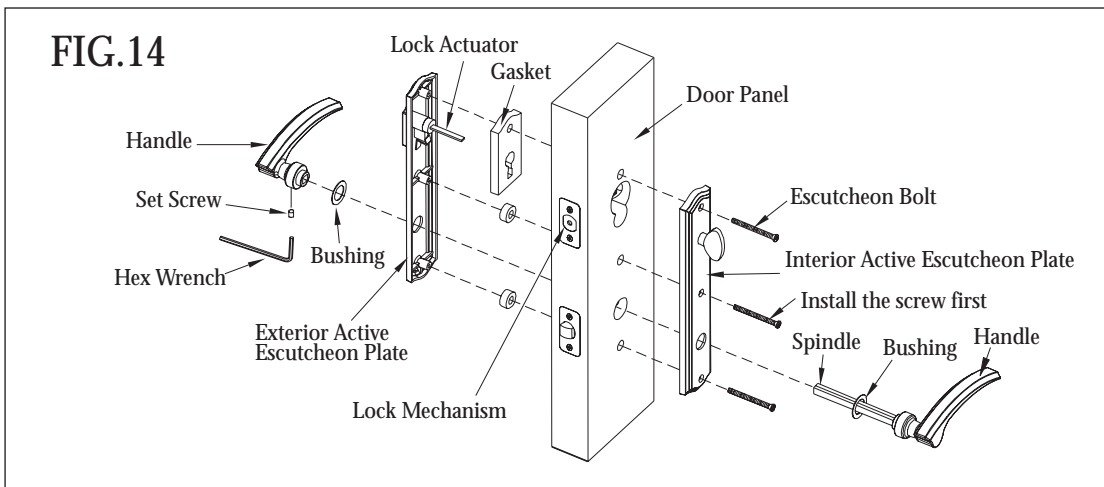

- Multi-point lock handle set. (See Fig.15)

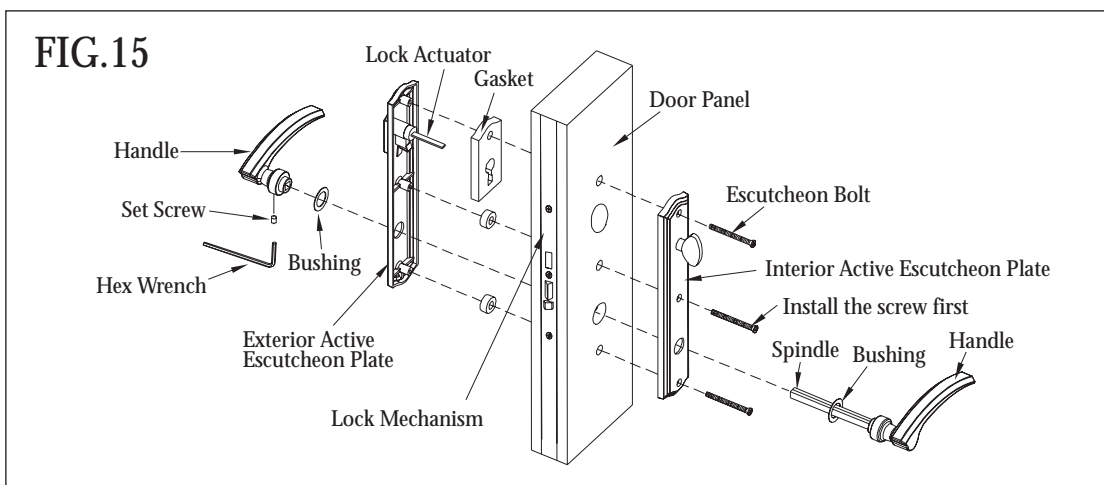

- Install two #10 x 3" screws through the outer holes of each hinge in the side jambs. Colored #10 x 3" screws have been provided to match the hinge color. (See Fig. 16)

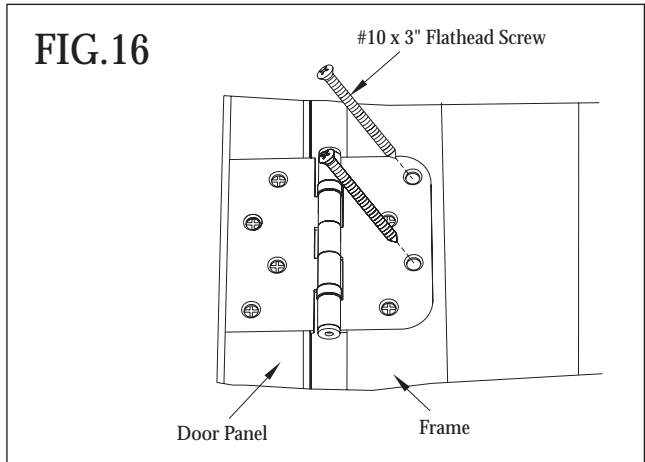

- Remove colored #9 x 7/8" screws in Top/Bottom Bolt Receiver Swing-in and replace with the same colored #9 x 3" screws for Swing-in Double French Door only. (See Fig.17)

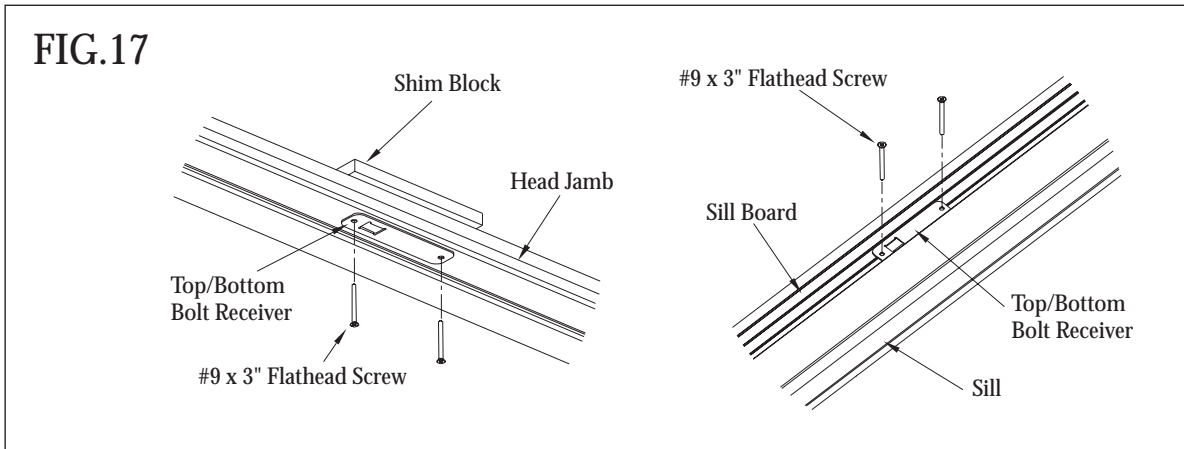

- Replace with and fasten the Hook Bolt Receiver and Latch Receiver using #9 x 3" screws. (See Fig.18)

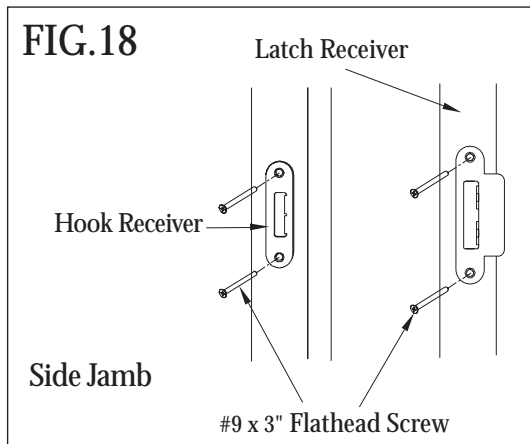

- Corner Pad. (See Fig.19)

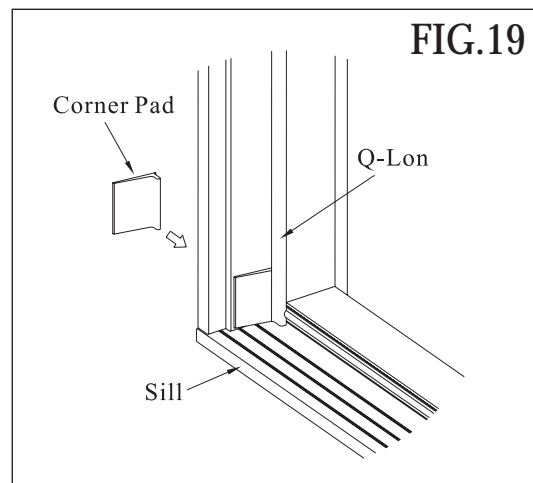

5. CHECK CLEARANCE AND SWING

- Unlock doors first inserting flat blade screwdriver into upper hole of door panel to turn dead bolt button vertically, then insert temporary handle set into lower hole and turn down to open door. (See Fig.20)

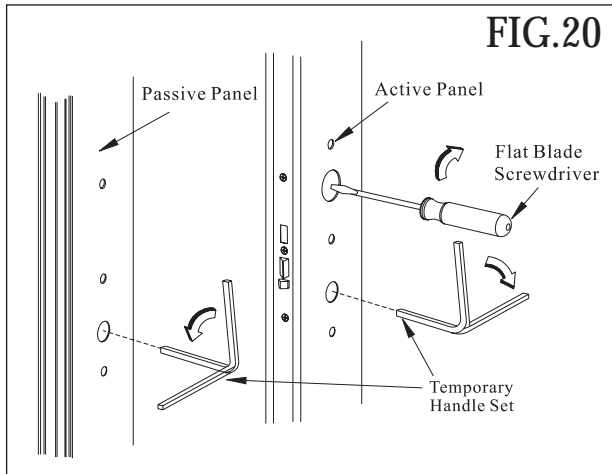

6. SEALING THE INSTALLATION

- Apply caulking on the top joints of the nailing fin. (See Fig.21)

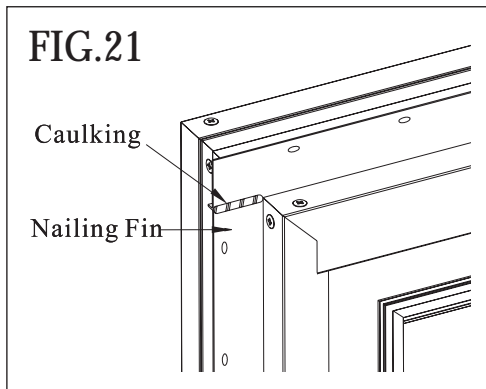

- Lap vertical strips of self sealing adhesive membrane (4" wide) onto the jambs' nailing fin and over the exterior sheathing.
- Install another layer of adhesive membrane lapping onto head jamb nailing fin and exterior sheathing. (See Fig. 22)
- Add insulation to air space between opening and unit.
- Caulk around entire perimeter of unit on "weather" side; seal brickmould to siding or facing, seal front bottom edge of sill, seal all joints between jamb and mouldings.

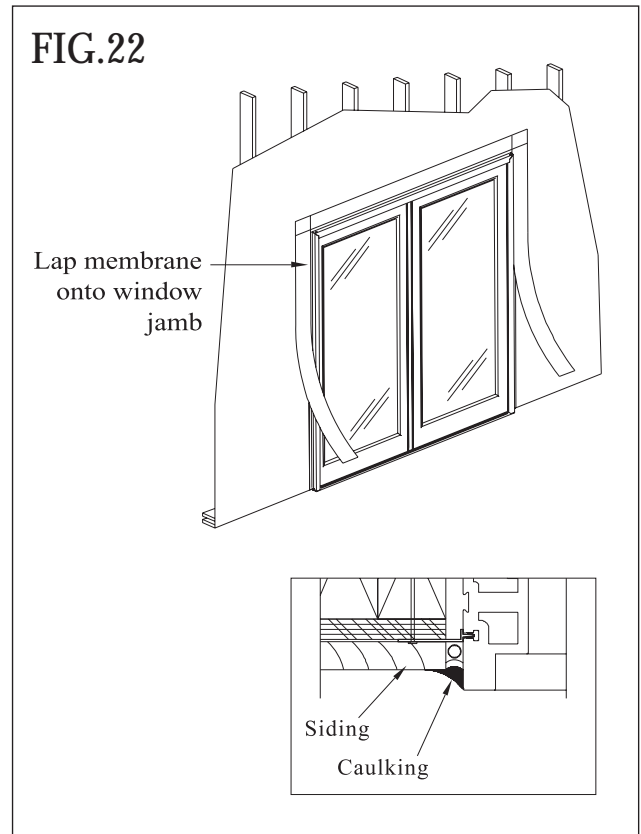

7. CLEANING INSTRUCTION

- Door and jamb skins may be cleaned with mild detergent and water.
- Do not use any solvent, acids or abrasives on the door and jamb skins.
- To clean the glass, use a soft clean grit-free cloth and mild detergent.
- Keep weep holes clean and clear of obstructions.